

Installation Manual

The **SIREN™** is an air flow monitor that provides visual and audible indications for air flow status. During normal operating conditions the **SIREN™** will show green LED bars indicating a safe condition. If the air flow drops below the set point, the **SIREN™** LED bars will flash red and give an audible alarm until the air flow returns to an acceptable condition or the silence button is pushed. The **SIREN™** also has a relay output, and night set back option.

Specifications

Operating Temperature: 60 - 100°F (16 - 37°C)
 Velocity Range: 40 - 2000 fpm (0.2 - 10.2 mps)
 Power: 12 - 24 VDC
 Input Current: 0.5 A Max
 Repeatability: 2%
 Relay input: Night Set Back
 Relay output: SPDT 2A @ 30 VDC
 Audible Alarm: 87 dB
 Probe Cable Length: 12ft (3.6m)
 Power Adapter Cable Length: 6ft (1.8m)

Optional

Power Adapter Extension Cable: 6ft (1.8m)

Dimensions

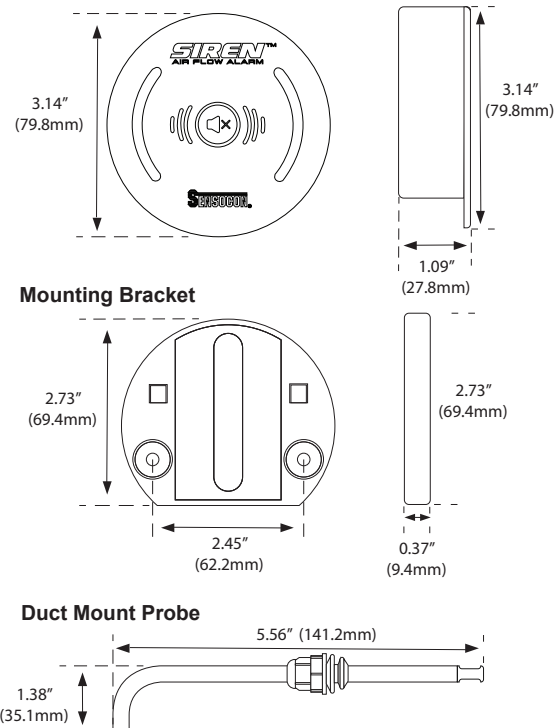

Duct Mount Probe Installation

1. Drill a 5/8" (16mm) hole into the air duct at a minimum of 12"(30mm) above the exhaust and 12"(30mm) below any bends in the duct.
2. Determine the probe insertion depth (approx. center of exhaust duct) and tighten the probe gland base (A) to that depth.
3. Insert the probe at an angle so that the duct is seated between the lip (B) and the fastener (C) of the probe gland.
4. Ensuring that the opening of the probe is facing the direction of the air flow, rotate the probe the rest of the way into the duct.
5. Tighten the probe to the duct by turning the fastener (C) counter-clockwise.

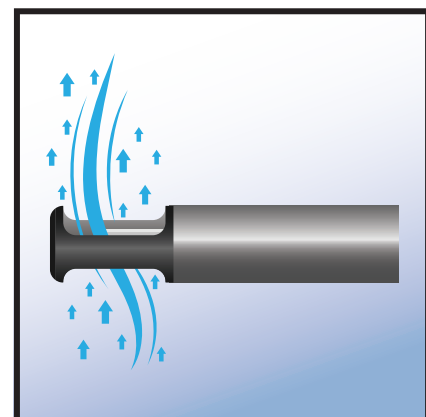
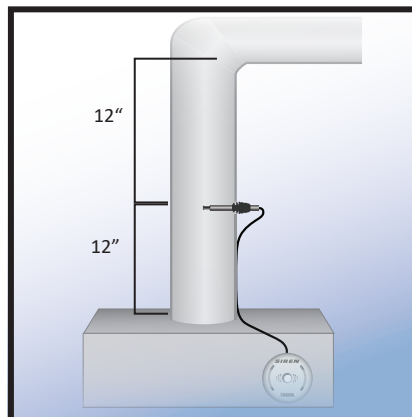
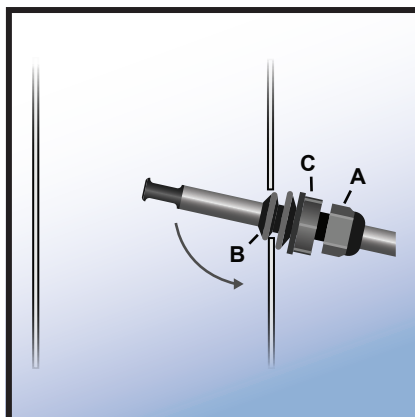

SIREN™ Installation

1. Select desired Dip Switch configuration (see Dip Switch Configuration).
2. Mount the unit either using the interlocking strips or the mounting bracket (See Mounting Options). Be sure to place the unit in an easily visible and reachable location.
3. Connect the power adapter and sensor probe via the ports located underneath the unit. The groove located on the back of the unit provides room for the cables to run behind the alarm.
4. Plug in the wall adapter and proceed to Calibration.
5. See the 6-Position Terminal below for hooking up the unit using a power source other than the wall adapter, relay output, and night setback input.

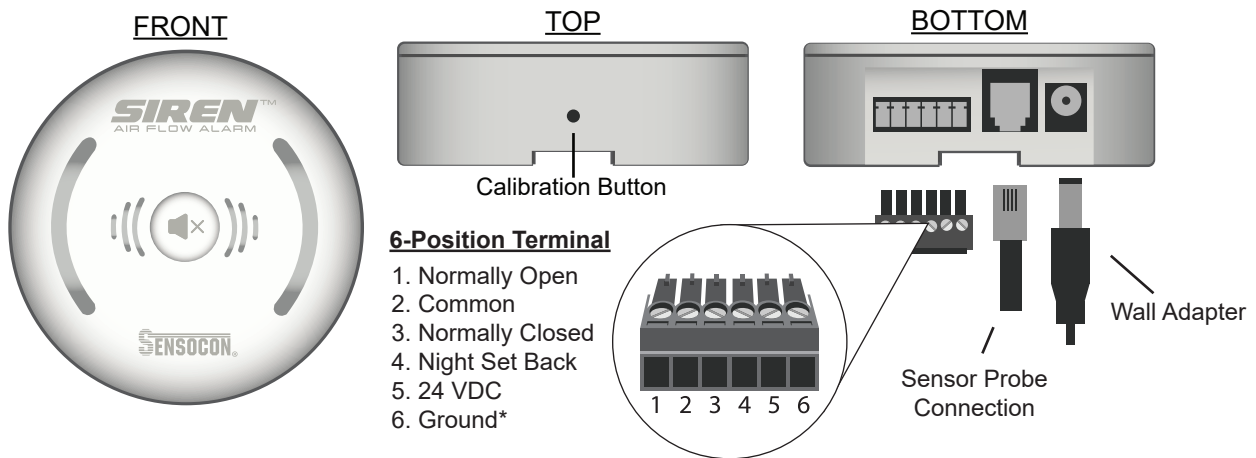

* ground is shared by power & Night Set Back

Dip Switch Configuration

- Dip 1- For calibration of set point- (ON)set point is at 80% of velocity at set-up, (OFF)calibrates the set point to current velocity.
- Dip 2- (ON)alarm will auto reset when proper velocity is achieved; (OFF)alarm condition latches (requires special reset).
- Dip 3- (ON)audible alarm will silence when button is pressed, but will sound again after 120 seconds; (OFF)audible alarm is permanently silenced when the silence button is pressed.

Dip Switch	1	2	3
Use	Alarm Set Point	Alarm Reset	Alarm Silence
On	Alarm point is set at 80% of velocity at set-up	Alarm will automatically reset when velocity returns to an acceptable range	When audible alarm sounds and the mute button is pushed, the audible alarm will sound again in 120 seconds if the velocity remains in an alarm condition.
OFF	Alarm point is set at the velocity at set-up	Alarm will latch and requires a 3 second hold of the silence button to reset Relay and Red LED. Audible alarm will automatically reset.	When audible alarm sounds, the mute button will permanently silence the audible alarm.

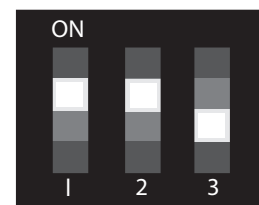
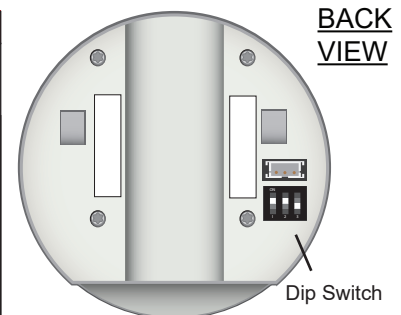

Calibration w/Dip Switch 1 on (Recommended)

1. Run the cabinet so that it achieves its normal operational air velocity.
2. Once the cabinet reaches operational air velocity, locate and hold down the calibration button found on top of the unit.
3. The unit will indicate calibration in progress with purple blinking LED bars.
4. Once the unit has successfully calibrated, a green light will flash 3 times.
5. If the calibration is unsuccessful, a red light will flash 3 times, possibly indicating turbulent flow.

Calibration w/Dip Switch 1 off

1. Run the cabinet at the desired minimum flow rate.
2. Once the cabinet reaches the desired minimum flow rate, locate and hold the calibration button found on top of the unit.
3. The unit will indicate calibration in progress with purple blinking LED bars.
4. Once the unit has successfully calibrated, a green light will flash 3 times.
5. If the calibration is unsuccessful, a red light will flash 3 times, possibly indicating turbulent flow.
6. Once the calibration is completed, return the cabinet to operational air velocity.
7. The unit will now alarm once the air velocity falls below the set minimum flow rate.

Night Set Back

The night set back option is used to disable the alarm while the cabinet is not in use. The alarm will illuminate blue while in night set back mode. To initiate night set back, provide a closure of pin 4 and 6. The alarm will go back into normal operation after the closure is removed.

Light Color Configuration

<u>Green</u>		Solid	Operational velocity is above set point
		Flashes 3 times	Calibration is complete
<u>Red</u>		Continuously flashing	Velocity has dropped below set point
		Flashes 3 times	Calibration was not successful
<u>Blue</u>		Solid	Night set back mode
		Slowly Flashing	Unit has not been calibrated
<u>Yellow</u>		Solid	Start Up
		Slowly Flashing	Sensor Fault
<u>Purple</u>		Slowly Flashing	Calibration in progress

Mounting Options

Interlocking Strip Mounting

1. Remove the plastic backing of both interlocking strips so that the adhesive sides are exposed. (Do not detach the interlocking strips)
2. With the interlocking strips still attached to the **SIREN™**, press the adhesive sides firmly to the preferred mounting surface.
3. Should the **SIREN™** need to be temporarily removed, detach one side of the strips from the other and later reattach in a similar fashion.

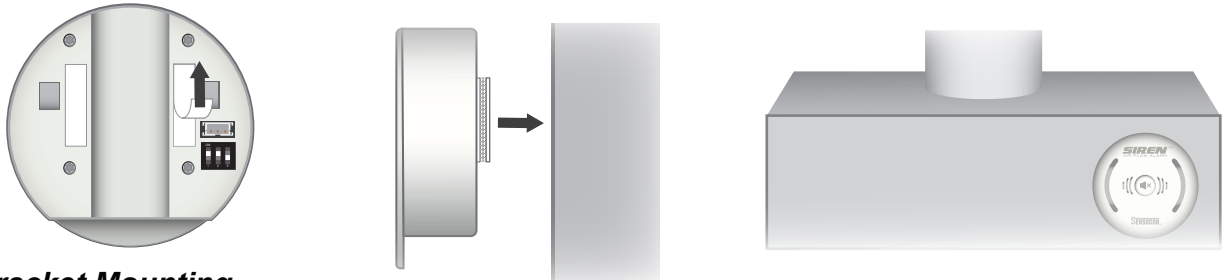

Bracket Mounting

1. With hooks facing upwards, use 3/8" hex self-drilling screws provided to mount the bracket to the preferred location.
2. Place the holes located in the back of the unit over the bracket hooks. The interlocking strips will not interfere with the mounting, as they fit within the groove of the bracket.
3. Gently pull the unit down onto the hooks until it clicks into place.

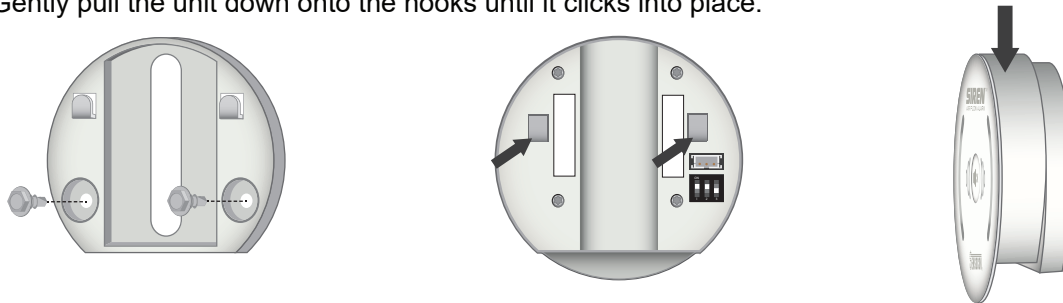

LIMITED WARRANTY

SENSOCON warrants its products to be free from defects in materials and workmanship for a period of one (1) year from the date of shipment, subject to the following terms and conditions: Without charge, SENSOCON will repair, replace, or refund the purchase price at SENSOCON's option products found to be defective in materials or workmanship within the warranty period; provided that:

- i. the product has not been subjected to abuse, neglect, accident, incorrect wiring not our own, improper installation or servicing, or use in violation of labels or instructions provided by SENSOCON;
- ii. the product has not been repaired or altered by anyone except SENSOCON;
- iii. the maximum ratings label and serial number or date code have not been removed, defaced, or otherwise changed;
- iv. examination discloses, in the judgment of SENSOCON, the defect in materials or workmanship developed under normal installation, use and service; and
- v. SENSOCON is notified in advance of and the product is returned to SENSOCON transportation prepaid before expiration of the warranty period.

THIS EXPRESS LIMITED WARRANTY IS IN LIEU OF AND EXCLUDES ALL OTHER REPRESENTATIONS MADE BY ADVERTISEMENTS OR BY AGENTS AND ALL OTHER WARRANTIES, BOTH EXPRESS AND IMPLIED. THERE ARE NO IMPLIED WARRANTIES OF MERCHANTABILITY OR OF FITNESS FOR A PARTICULAR PURPOSE FOR GOODS COVERED HEREUNDER.